

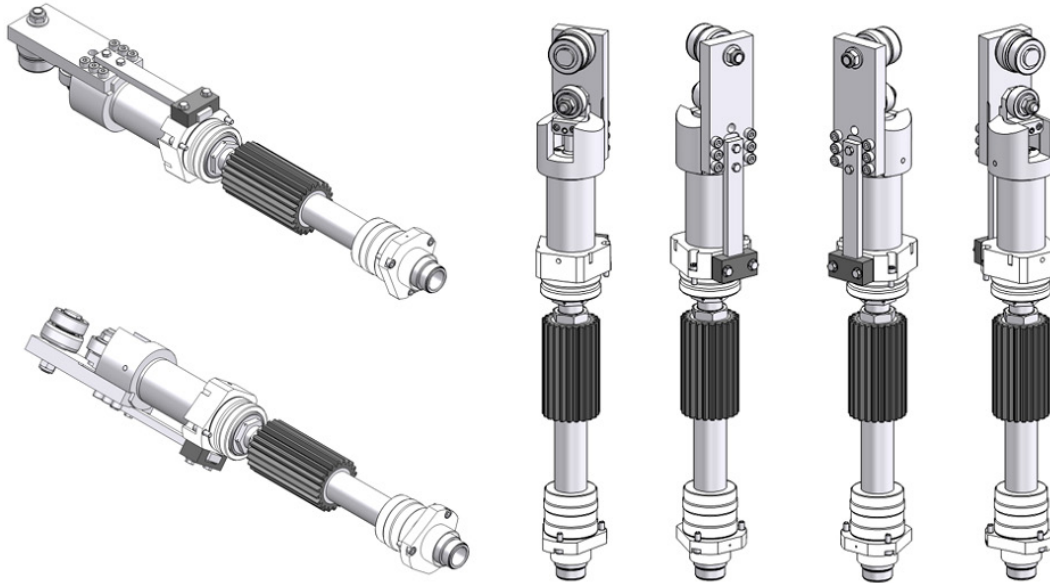

LUBE-FREE HEAD SLIDE



For screw-on capping machines

New!! Upgrade your current head slide to a **new lube-free head slide**.

BENEFITS

- **Helps reduce the contamination risks**
- No risk of oil drips along the shaft
- Easier maintenance (no planning for lubrication, saving of time)
- **Can be adapted on existing cappers**
- No change of settings of the machine
- Simplification: no lubrication oil purchase and inventory management

HOW TO PROCEED?

- During a maintenance shutdown of the line, remove the existing slides and put the lube-free slides. It is a simple **maintenance operation taking only approx. 15mn.**
- The upgrade can be performed by a Zalkin technician, on request.
- Lube-free head slides do not require any intervention for 24 months.
- The synthetic bushing of the lube-free slides needs to be replaced every 12,000 hours.